

Prisma™ 80

Quadrupole Mass Spectrometer

QMS 200

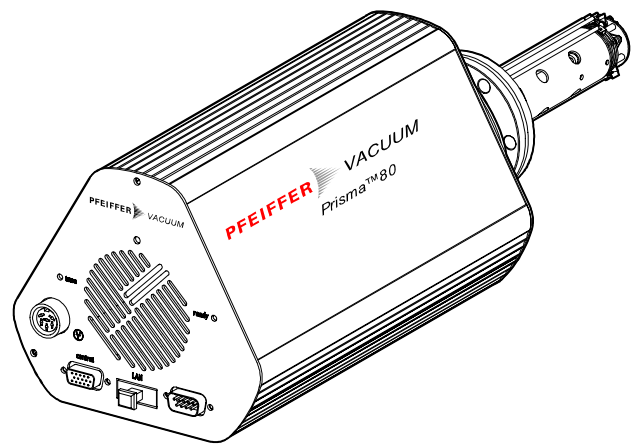

CE

Product Identification

In all communications with Pfeiffer Vacuum, please specify the information on the product nameplates. For convenient reference copy the information for all items of your system into the space provided below.

QME 200

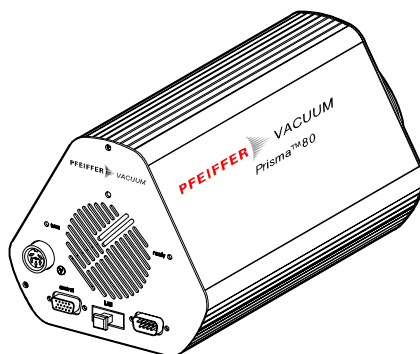

Pfeiffer Vacuum, D-35614 Asslar	
Typ:	
No:	
F-No:	
...V=	...A

QMA 200

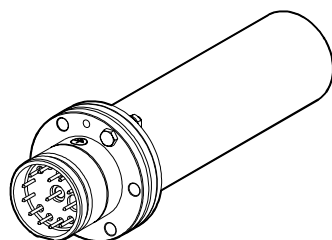

Typ:	No:	F-No:	Pfeiffer Vacuum D-35614 Asslar
------------	-----------	-------------	-----------------------------------

Software TalkStar

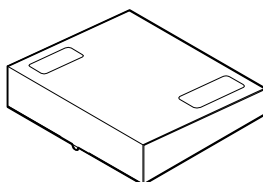

Pfeiffer Vacuum D-35614 Asslar	
TalkStar	
Version: x.xx	
No: 450-490	
Copyright (C)	

Validity

This document applies to products with part numbers

PTM04100	comprising
PTM25250	(Analyzer)
PTM28515	(Electronics)
B 5181 408 KY	(Power supply)

The part numbers can be taken from the product nameplates.

This document is based on firmware number

BG 509 725 –H (or higher)
450-465 (or higher)

If the product does not work as described in this document, please check that it is equipped with the above firmware version (→ [1]).

We reserve the right to make technical changes without prior notice.

Intended Use



The Prisma mass spectrometer is designed for partial pressure analysis at pressures $<10^{-4}$ mbar. Typical applications are measurement, monitoring and process control functions in vacuum systems.

Trademarks

Prisma™	INFICON AG
Windows™	Microsoft Corporation

Contents

Product Identification	2
Validity	2
Intended Use	2
Trademarks	2
1 Safety	4
1.1 Symbols Used	4
1.2 Personnel Qualifications	4
1.3 General Safety Instructions	5
1.4 Liability and Warranty	5
2 Technical Data	6
2.1 Standards Complied With	6
2.2 Ambient Conditions	6
2.3 Prisma™ 80	6
2.4 QME 200	7
2.5 SP 200	7
2.6 Pin Assignment	8
3 Installation	10
3.1 Unpacking	10
3.2 Installation	10
3.2.1 Space Requirements [mm]	11
3.2.2 Required Tools	11
3.2.3 Installing the QMA	12
3.2.4 Installing the QME	13
3.3 Electrical Connections	13
3.3.1 Connecting the QME	13
3.3.2 Connecting the SP 200 Power Supply to the Prisma	14
3.3.3 Connecting the PC	15
3.4 Installing the Software	15
4 Operation	16
4.1 First Time Operation	16
4.2 Software Operation	17
4.3 Settings	21
4.3.1 Tuning the RF Generator	21
4.3.2 Optimizing the Ion Source Sensitivity	21
5 Maintenance	22
5.1 QMA	22
5.1.1 Changing the Filament	22
5.2 QME	24
5.2.1 Cleaning the Housing	24
5.2.2 Cleaning the Dust Filter	24
5.2.3 Replacing the Filter Mat	24
5.2.4 Tuning the RF Generator	25
5.2.5 Optimizing the Ion Source Sensitivity	26
5.2.6 Replacing the QME	28
6 Accessories and Spare Parts	29
7 Returning the Product	30
8 Disposal	30
Appendix	31
A: Literature	31
Declaration of Contamination	32
Declaration of Conformity	33

For cross-references within this document, the symbol (→  XY) is used, for cross-references to other documents, the symbol (→  [Z]).

1 Safety

1.1 Symbols Used

DANGER

Information on preventing any kind of physical injury.



WARNING

Information on preventing extensive equipment and environmental damage.

Caution

Information on correct handling or use. Disregard can lead to malfunctions or minor equipment damage.

 The result is O.K.

 The result is not as expected.

 The lamp/display is lit.

 The lamp/display flashes.

 The lamp/display is dark.

Labeling

1.2 Personnel Qualifications

Skilled personnel

All work described in this document may only be carried out by persons who have suitable technical training and the necessary experience or who have been instructed by the end-user of the product.

1.3 General Safety Instructions

- Adhere to the applicable regulations and take the necessary precautions for the process media used.
Consider possible reactions between the materials and the process media.
Consider possible reactions of the process media due to the heat generated by the product.
- Adhere to the applicable regulations and take the necessary precautions for all work you are going to do and consider the safety instructions in this document.
- Before beginning to work, find out whether any vacuum components are contaminated. Adhere to the relevant regulations and take the necessary precautions when handling contaminated parts.

Communicate the safety instructions to all other users.

1.4 Liability and Warranty

Pfeiffer Vacuum assumes no liability and the warranty becomes null and void if the end-user or third parties

- disregard the information in this document
- use the product in a non-conforming manner
- make any kind of interventions (modifications, alterations etc.) on the product
- use the product with accessories not listed in the corresponding product documentation.

The end-user assumes the responsibility in conjunction with the process media used.

Training



Training

Pfeiffer Vacuum offers application, operating and maintenance courses for the best use of this product. Please contact your local Pfeiffer Vacuum representative.

2 Technical Data

2.1 Standards Complied With

Safety	
QME/QMA	EN 61010-1:1993 IEC1010-1:1990 +A1:1992 Protection class I
SP 200	DIN EN 60950 IEC 950, UL 1950 CSA 22.2 No. 234
EMC	
Immunity	EN 50082-2
Emission	EN 50081-1

2.2 Ambient Conditions

Operation	Indoors only
Altitude max.	2000 m NN
Degree of protection	IP 30
Pollution degree	2
Temperatures	
Storage/transport	-25 ... +70 °C
Operation QME	0 ... +40 °C
SP	0 ... +40 °C
Relative humidity	Max. 80% up to 31 °C, Linearly decreasing to 50% at 40 °C

2.3 Prisma™ 80

Mass range	1 ... 80 u
Detector type	Faraday
Detection limit	$<1 \times 10^{-12}$ mbar
Unit resolution (valley, full mass range) at 10% peak height adjustable to	<10% 0.5 ... 2.5 u
Sensitivity to argon	$>1 \times 10^{-3}$ A/mbar
Contribution to neighboring mass 40/41	<10 ppm
Operating pressure	$\leq 1 \times 10^{-4}$ mbar $\leq 1 \times 10^{-3}$ mbar at an emission <200 µA
Reproducibility of peak ratio (constant conditions over 8 h, N ₂ and Ar from air)	±0.5%
QMA operating temperature	0 ... +150 °C
Bakeout temperature (QME removed)	≤200 °C
HS ion source	Open design, radial symmetry, 2 filaments (yttrium oxide), degassing by electron bombardment (10 mA, 300 V)
Mounting orientation	Any (→ 12)
Weight	3 kg
Connection flange	DN 40 CF

2.4 QME 200

Measurement channels	64
Measurement modes	Scan analog, Scan Bargraph, MID
Measurement cycles	Single- / Multi-channel 1 ... 9999 Cycles or Repeat
Measurement data buffer	128 Kbytes
MID dwell	10 ms ... 60 s
Measurement speed Scan Analog + Bargraph Peak Scan Bargraph Stair	200 ms/u ... 60 s/u 20 ms/u ... 60 s/u
Electrometer amplifier	10^{-5} ... 10^{-12} A (f.s.), fix and autorange
Signal filter	FIR filter
Power supply	24 VDC / 2.0 A
Interfaces RS-232-C LAN	300 ... 19200 bit/s Arcnet, fiberoptic (≤ 1000 m) 2.5 Mbit/s
Inputs	TalkStar does not support the inputs
Outputs 2 relays	Normally open contact, 24 VAC, 30 VDC, 1 A TalkStar does not support any additional outputs
Weight	2.5 kg

2.5 SP 200

Voltage	90 ... 260 VAC
Frequency	47 ... 63 Hz
Power requirements	1.5 A @ 115 V / 60 W 0.8 A @ 230 V / 60 W
Output voltage	24 VDC, stabilized
Insulation	≥ 10 M Ω , output to ground
Overvoltage category	II (according to EN 61010)
Weight	0.7 kg

2.6 Pin Assignment



TalkStar does not support the gauge connection.

control

Pin	Assignment
1	1)
2	1)
3	1)
4	1)
5	1)
6	1)
7	1)
8	1)
9	1)
10	1)
11	REL_1A
12	REL_1B
13	REL_2A
14	REL_2B
15	GND
Case	Shield

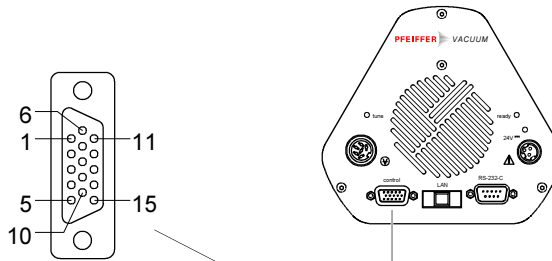

D-Sub H-Density
15-pin, female

1) TalkStar does not support this function.



WARNING

If this connection is used, a shielded cable is required for EMC reasons. The shield must contact the connector housing. The opposite end should remain open or be grounded so that no damaging compensating currents can occur.

LAN

TalkStar does not support the LAN interface.

RS-232-C

Pin	Assignment
1	n.c.
2	Received Data (RXD)
3	Transmitted Data (TXD)
4	Data Terminal Ready (DTR) *)
5	Signal Ground (SGND)
6	n.c.
7	Request To Send (RTS) *)
8	Clear To Send (CTS) *)
9	n.c.
Case	Shield

*) optional signal

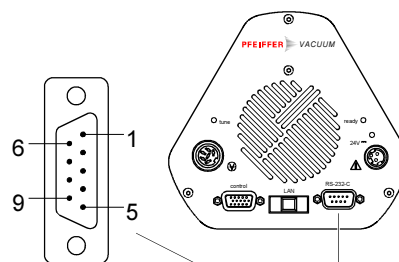

D-Sub
9-pin, male



WARNING

If this connection is used, a shielded cable is required for EMC reasons. The shield must contact the connector housing. The opposite end should remain open or be grounded so that no damaging compensating currents can occur.

24 VDC

Pin	Assignment
1	+24 VDC
2	GND
3	GND
Case	Screen

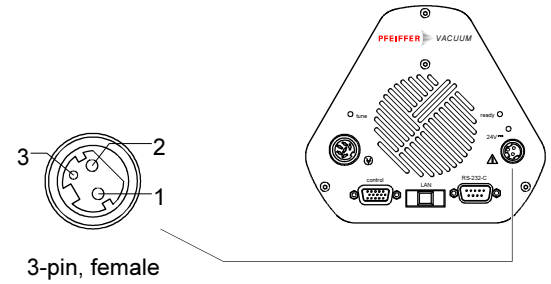

QMA

STOP DANGER

This connection carries hazardous voltages.

Pin	Assignment
1	Reserve
2	Extr
3	Focus
4	HV-
5	Filament 1
6	Filament 2
7	Anode
8	RF-
9	GND
10	GND
11	RF+
12	Filament Common
13	EP

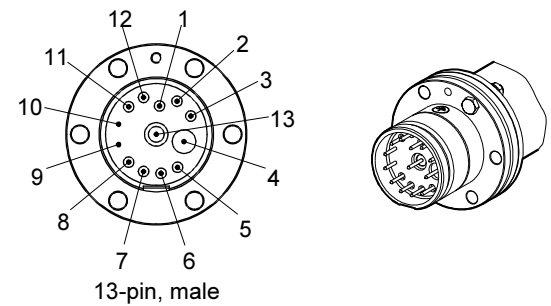

3 Installation

3.1 Unpacking



Store the transport safety devices and re-install them before transporting the product again.

3.2 Installation



DANGER

Voltages up to 330 VDC appear on the QMA 200 during operation.

Other components in the vacuum chamber (e.g. gauges) may possibly be exposed to this voltage under unfavorable conditions. If as a result, such parts (including the lines and connected equipment!) become hazardous, they must be arranged or protected in such a way that no sparkover and charge transfer can occur.

If the QMA can be touched while the vacuum system is open, additional protection is needed, e.g.:

- mechanical protection against touching
- forced disconnection of the SP 200 power supply when the system is opened.



DANGER

External hazardous voltages (e.g. due to contact, sparkover, plasma, ion or electron beams) must not be allowed to be transferred to the electrodes of the QMA 200. If such danger sources exist in the vacuum chamber, additional safety measures (e.g. better placement, shielding, grounding, etc.) must be taken that reliably prevent such influences. Also lower external voltages acting on the QMA may damage the electronics and lead to unreliable measurement results. Suitable precautions as mentioned above are to be taken.



WARNING

The QMA must be correctly installed from a vacuum engineering point of view, i.e. the gases to be detected must have unhindered access to the analyzer. Vacuum coating of the analyzer must be prevented.



Caution



Caution: vacuum component

Dirt and damages impair the function of the vacuum component.

When handling vacuum components, take appropriate measures to ensure cleanliness and prevent damages.

3.2.1 Space Requirements [mm]

QMA 200, QME 200

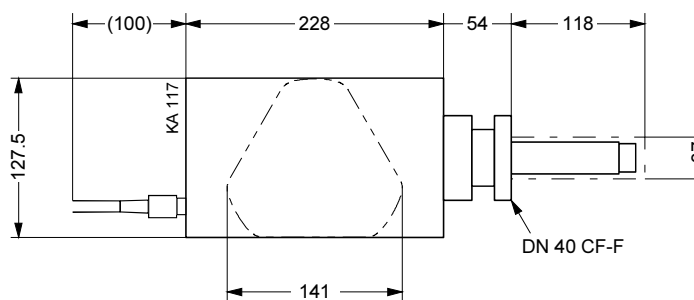

Caution

The QMA 200 may only be installed in flanges or tubes with an internal diameter ≥ 37 mm, otherwise short circuits to the wall can occur.

Note the required installation depth. Do not kink the cables.

SP 200

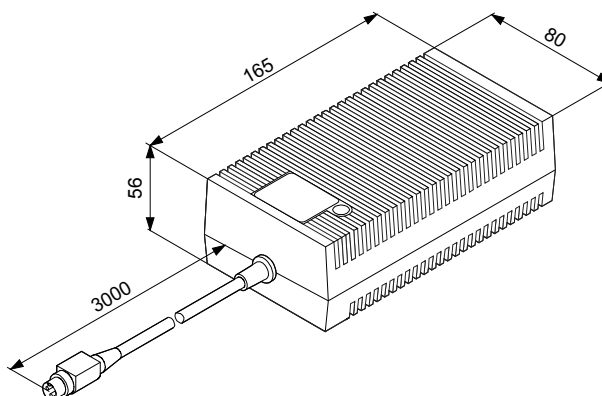

3.2.2 Required Tools

- 4 mm hexagon socket screw key
- 10 mm open-end wrench (2 pieces)
- Screwdriver (blade width 3 ... 4 mm)

3.2.3 Installing the QMA



DANGER

The analyzer flange must be properly grounded.

- Connect it with all 6 screws to the properly grounded vacuum system.
- If the vacuum system is not grounded, connect the QMA flange (grounding screw M4) to ground by means of a separate ground conductor.

Establish this connection with yellow/green insulated or bare stranded copper wire:

- 2.5 mm² if mechanically protected according to DIN VDE 110 T540
- 4.0 mm² if not protected

Caution

The QMA should preferably be mounted horizontally (with the guiding groove downward). This results in optimum protection of the QME against falling objects and allows easy installation and excellent access to the front panel.

Removing the transport tube and flanging the analyzer to the vacuum chamber

Caution

Caution: dirt sensitive area
Touching the product or parts thereof with one's bare hands increases the desorption rate.
Always wear clean, lint-free gloves and use clean tools when working in this area.

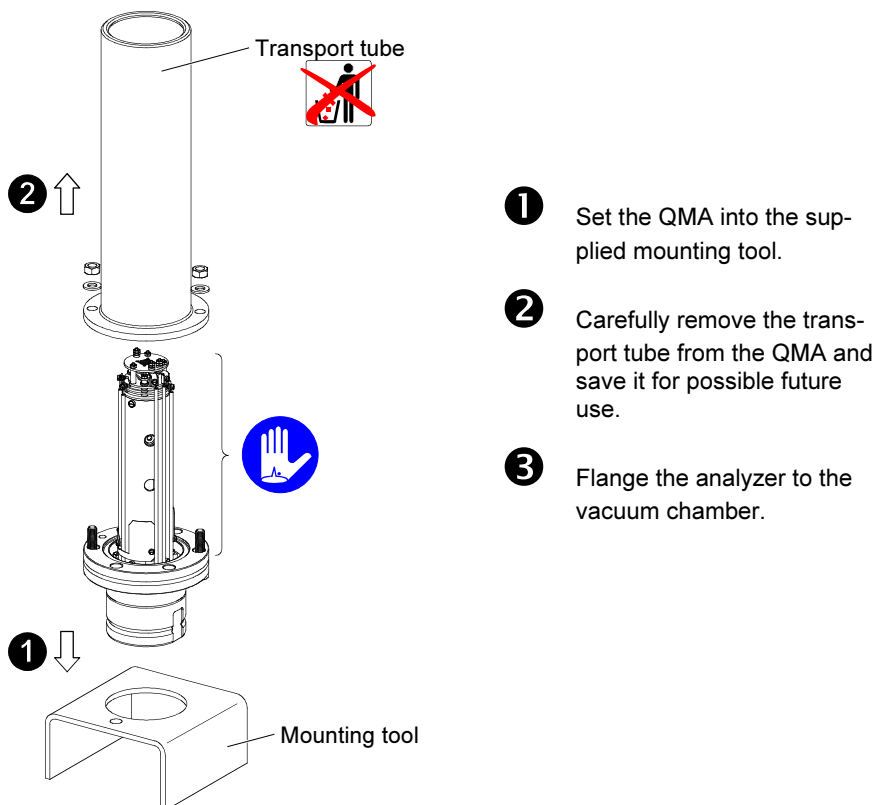

3.2.4 Installing the QME

DANGER

The QME may be mounted only to a correctly installed QMA as the only ground connection is established via the QMA flange.

The 24 V feeder line from the SP 200 must never be connected if the QMA is not screw fastened to the QME.

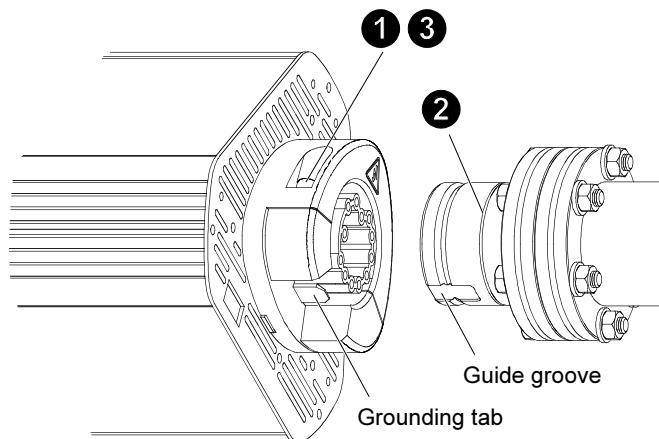

- 1** With a 4 mm hexagon socket screw key loosen the two screws on the black plastic connection piece of the QME so that the moving part has a play of 2 ... 3 mm.
- 2** Carefully slide the QME onto the mounted QMA up to the notch mark. Make sure the positioning is correct (watch the grounding tab of the QME and the guide groove of the QMA). Do not apply excessive force.
- 3** Firmly tighten the two hexagon socket screws. These screws secure the QME mechanically and ensure electrical safety by providing ground contact.



3.3 Electrical Connections



WARNING

All electrical connections must have cable strain relief. Route the cables separately from EMI sources.

3.3.1 Connecting the QME



WARNING

For reasons of electromagnetic compatibility, a single central grounding point is strongly recommended for all connected units (pumping station, SP 200, computer, recorders, etc.). A multiple AC power outlet or a common line voltage distributor with power switch fulfills this requirement in a simple manner.

3.3.1.1 Connection

TalkStar does not support the gauge connection.

3.3.1.2 control Connection

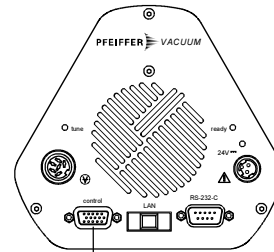

Digital input	Digital outputs	Analog inputs	Analog outputs
TalkStar does not support this function.	Switching thresholds or e.g. open/close valve	TalkStar does not support this function.	TalkStar does not support this function.

Specifications and pin assignment of connectors → 7, 8

Digital output

2 isolated relay contacts (N.O.). They can be assigned to the switching functions (peak height monitoring) or be used as software-controlled outputs (e.g. for valve actuation).

Signal designation: REL_1A ; REL_1B ⇒ DO 0
 REL_2A ; REL_2B ⇒ DO 1
 Logic assignment: DO .. = true ⇒ Contact closed

3.3.2 Connecting the SP 200 Power Supply to the Prisma

WARNING
 Do not yet plug in the SP 200 power plug (→ 16).

- 1** Set up the power supply in such a way that:
 - it cannot get wet e.g. by spilled water on the floor
 - air circulation is not impeded and the ambient conditions are met.
- 2** Insert the outlet connector of the SP 200 into the **24 VDC** connector of the QME.

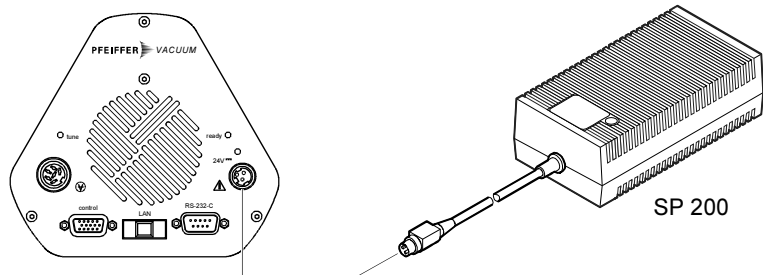

3.3.3 Connecting the PC

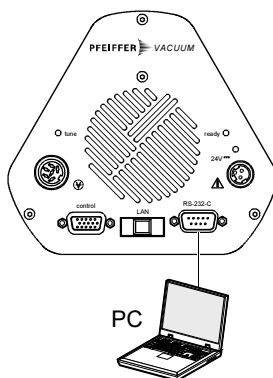

RS-232-C interface:

Use the supplied 9-conductor null modem cable. (If required use the extension cable.)
 → [1]

LAN interface:

TalkStar does not support the LAN interface.

3.4 Installing the Software



TalkStar is a 32 bit software and requires Windows™ 95, 98 ,ME, NT or 2000.

Install the enclosed TalkStar software as follows:

- 1 Turn on the PC and start the operating system.



- 3 Follow the instructions of the installation program.

After the installation has been successfully completed, the program can be started from the Start menu under "Programs" – "TalkStar" or via the Desktop by clicking the icon.

4 Operation

4.1 First Time Operation

DANGER



Caution: damaged product

Putting a damaged product into operation can be extremely hazardous.

In case of visible damages, make sure the product is not put into operation.

DANGER



Caution: line voltage

Incorrectly grounded products can be extremely hazardous in the event of a fault.

Use only a 3-conductor power cable with protective ground. The power connector may only be plugged into a socket with a protective ground. The protection must not be nullified by an extension cable without protective ground.

WARNING



Check the pressure in the QMA before you insert the power plug of the SP 200. The pressure must be $<10^{-4}$ mbar.

WARNING



Do always make sure that the limits values specified in the Technical Data (→ 6) are not exceeded and that the ambient conditions are met.

SP 200

Insert the power plug.

WARNING

The power plug should be easily accessible. If this is not the case at the installation site, a power switch or connector must be provided at an easily accessible location.

QME

WARNING

The QME may only be turned on and off by inserting or detaching the power plug.

	LED Status	Function	Remedial action
		24 V supply available	---
		24 V supply not available	Check the line voltage + power connection
		Ready for operation	---
		Not ready	Contact Pfeiffer Vacuum Service Center

TalkStar Software

Start the TalkStar software in the Start menu under "Programs" – "TalkStar" or via the Desktop by clicking the icon.

4.2 Software Operation

General

Talkstar allow access to many settings and functions via a context menus. Context menus are activated by clicking the corresponding item with the right mouse button.

Measurement

Once you have started Talkstar, you can access all available recipes via the "Recipes" entry in the tree.

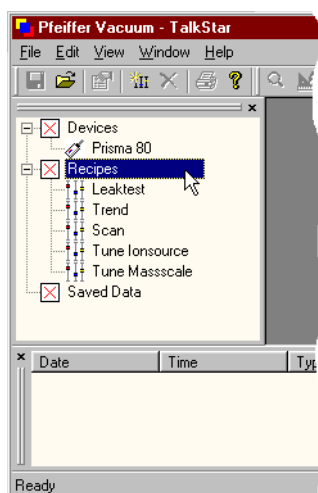

When the recipes are started with a double click, the Prisma automatically goes online, activates the emission if necessary and starts measuring.

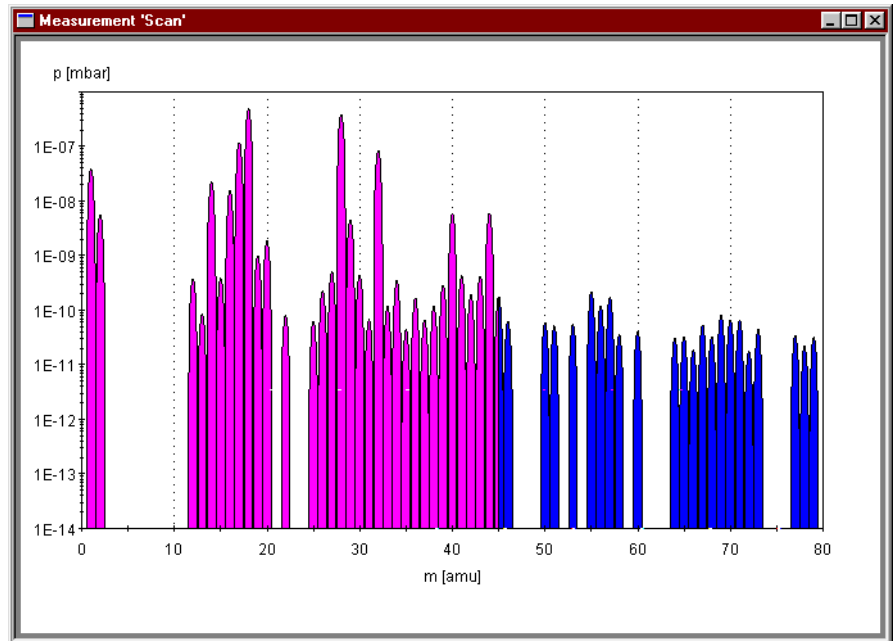
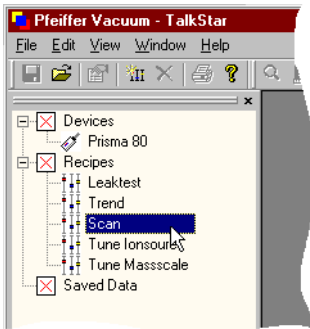
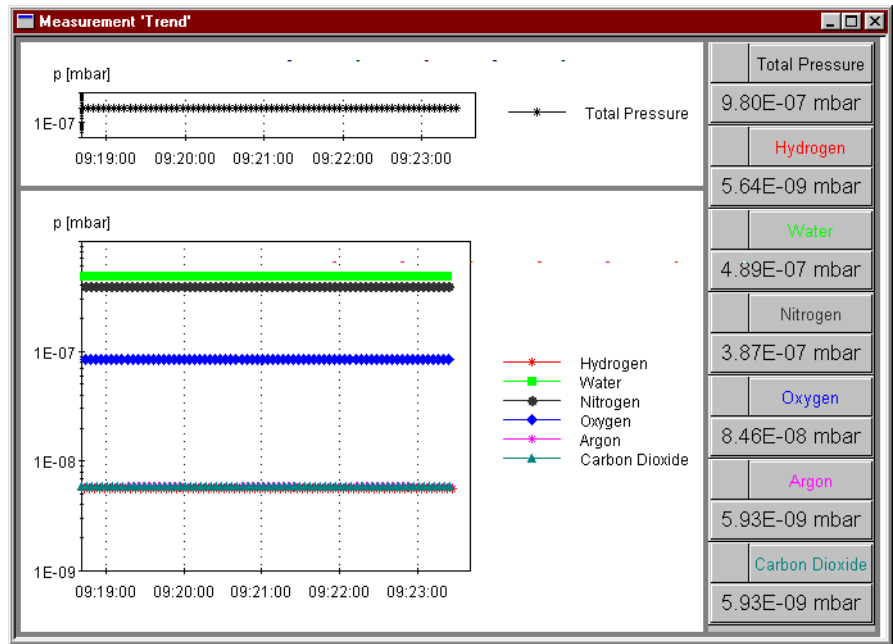
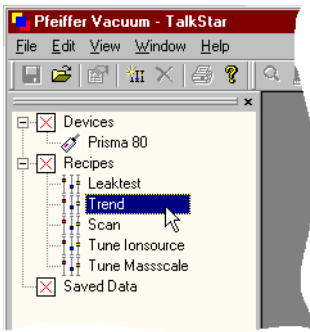

The Y axis can be switched from "Ion Current" to "Partial Pressure" and vice-versa.



Definition of mass dependent calibration factors

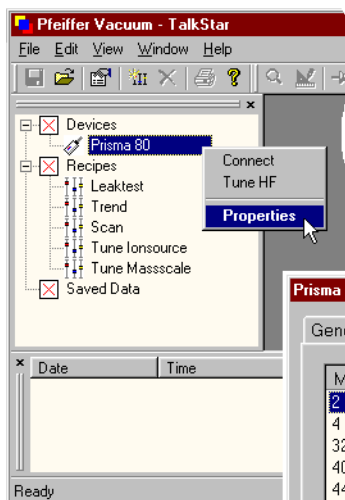

The properties of the Prisma are accessed via the "Prisma 80" context menu. You can access the mass dependent calibration factors on the "Calibration Factors" page.

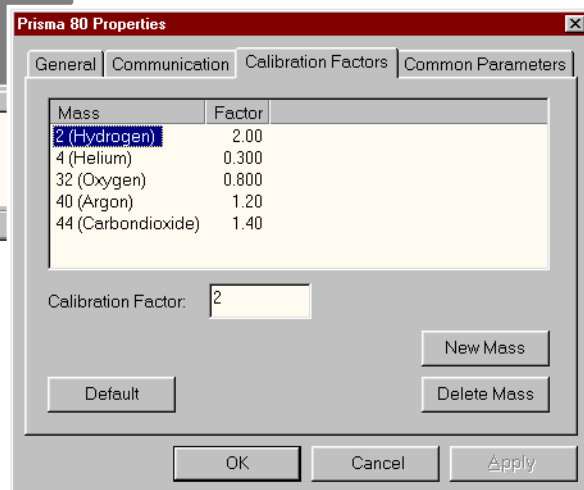

Parameterizing in the measurement data display

When a recipe has been started and the measurement data are displayed, you can access a parameter by double clicking the corresponding curve.

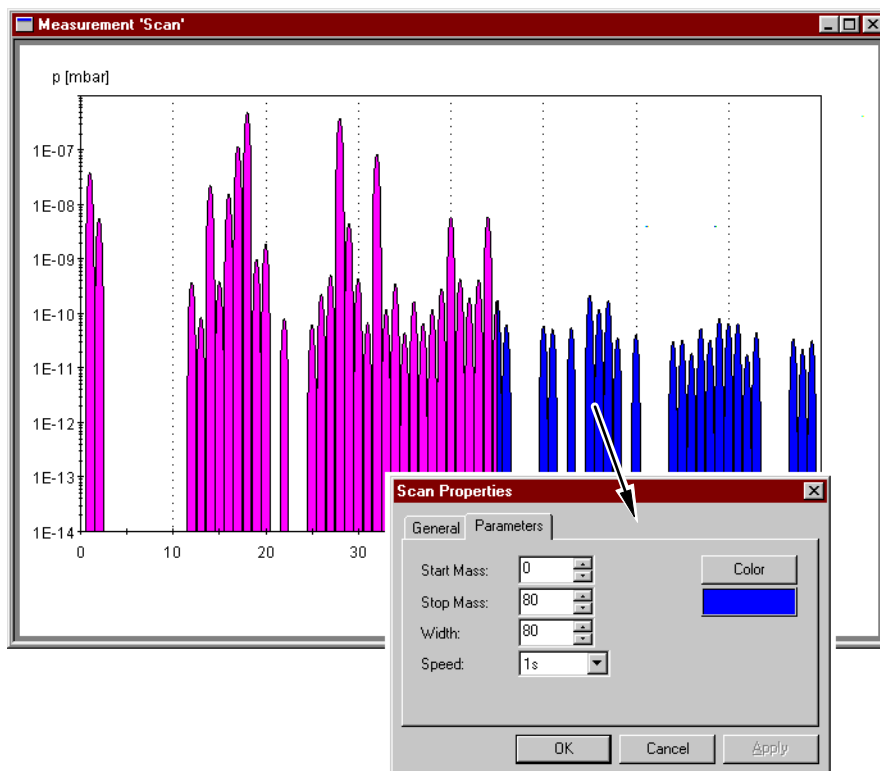

Addition and removal of components / scans

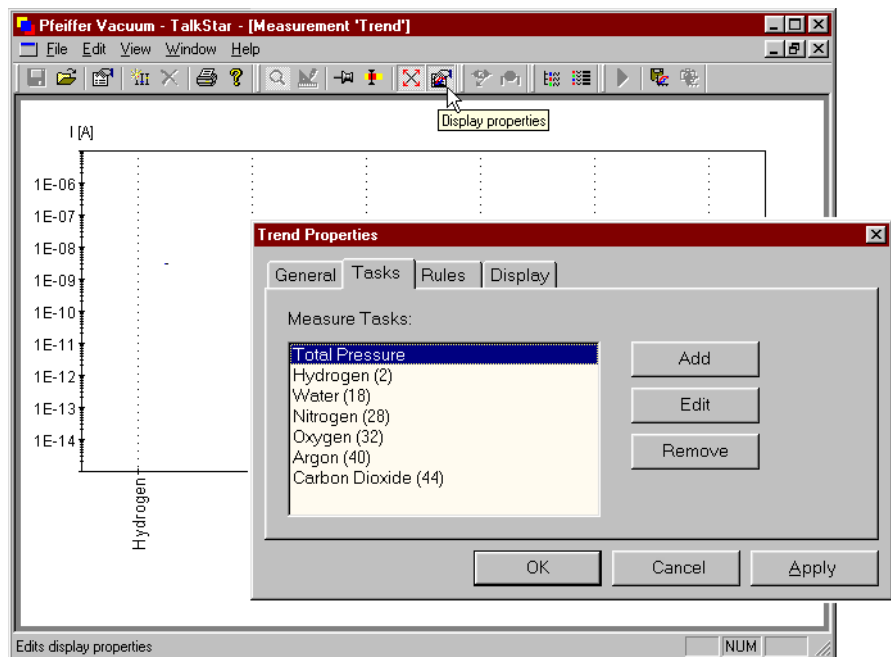

In the Measurement data display, all settings of the currently active recipe can be accessed by clicking the "Display Properties" button. On the "Tasks" page, components / scans can be added or removed.



As soon as the new settings have been confirmed with OK, they are applied in the (current) measurement.

Recording measurements

Measurement data can be recorded online.

- To start recording, choose the icon  on the tool bar.
⇒ Use a file name in the syntax supported by Windows. The extension *.tdf (TalkStar Data File) is automatically added.
- To finish recording, click the icon  on the tool bar again.

To access the recorded data, select the corresponding file under "Saved Data".

Printing of diagrams

To print individual diagrams, proceed as follows:

- 1** Start a recipe or load data from the memory.
- 2** In the window that is subsequently displayed, select the desired diagram.
- 3** Click the printer symbol  on the tool bar.

Shutting TalkStar down

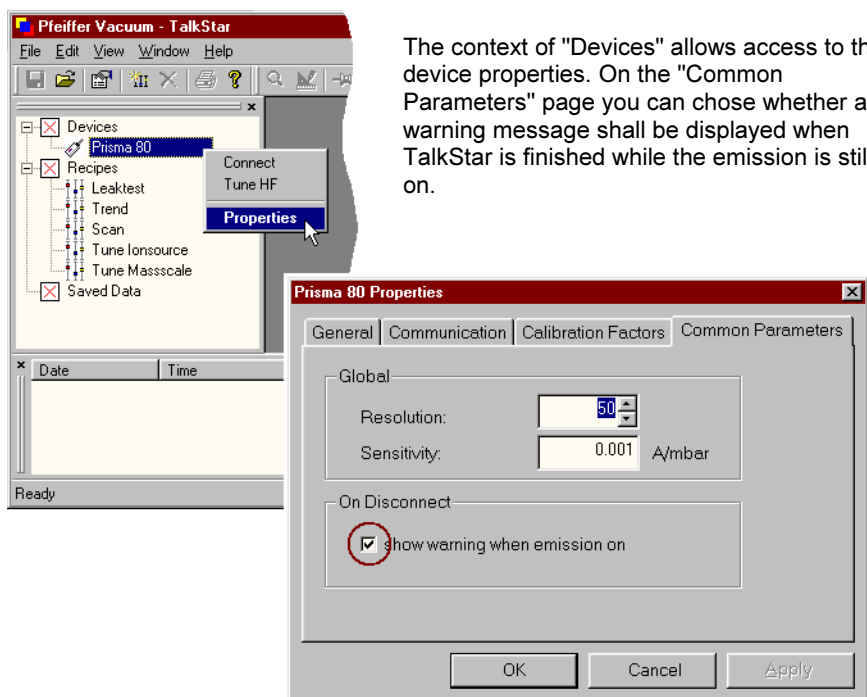

If you are going to quit TalkStar only for a short time, preferably leave the emission on in order to obtain stable measurement readings immediately upon starting the program again. Before prolonged interruptions of the measurement and especially before the system is vented, make sure the emission is switched off.



After switching the filament off, wait >5 minutes before venting the system in order for the ion source to cool down sufficiently.

4.3 Settings

4.3.1 Tuning the RF Generator

Correct tuning assures optimum measurement accuracy over the entire mass range. The RF circuit has to be tuned (→ 25):

- upon exchange of the analyzer or electronics^{*)}
- when a corresponding error message is displayed.

An annual tuning check is also recommended.

4.3.2 Optimizing the Ion Source Sensitivity

When the Prisma is used for the first time, the factory parameter settings of the ion source are applied (→ 26). TalkStar reads these parameter values when it starts communication with the Prisma.

^{*)} If the analyzer and electronics have not been delivered together as one unit, the RF circuit has to be tuned when the unit is put into service for the first time.

5 Maintenance

5.1 QMA

5.1.1 Changing the Filament



Skilled personnel

Filaments are supplied as preassembled units. They should only be changed by qualified personnel.



Caution



Caution: dirt sensitive area

Touching the product or parts thereof with one's bare hands increases the desorption rate.

Always wear clean, lint-free gloves and use clean tools when working in this area.

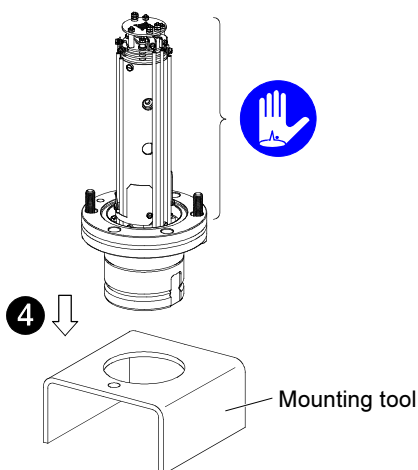

- 1 Detach all electrical connections to the QME.
- 2 Separate the QME from the analyzer (by performing the steps in Chapter 3.2.4 in reverse order).
- 3 Detach the analyzer from the vacuum chamber.
- 4 Place the analyzer into the supplied mounting tool.

- 5 Grip the U-section with flat-nose pliers and loosen the screw by 2 turns.
- 6 Remove the nut.
- 7 Carefully pull the filament assembly upward.
- 8 Dispose of the used filament assembly.

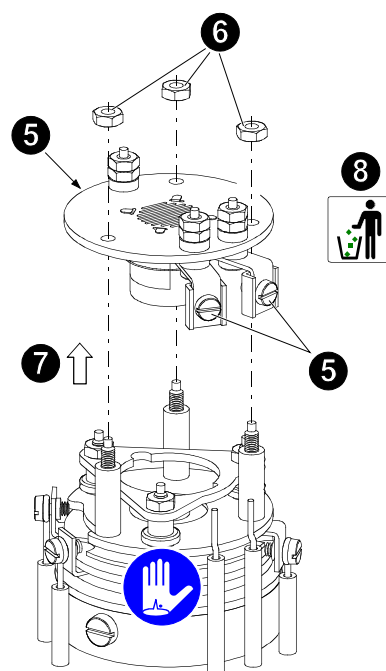

- 9 Open the packing tube of the spare filament assembly. Carefully lift off the support bracket while gripping the filament assembly at the base of the protective packing.



Do not touch the filament, not even with gloved hands.

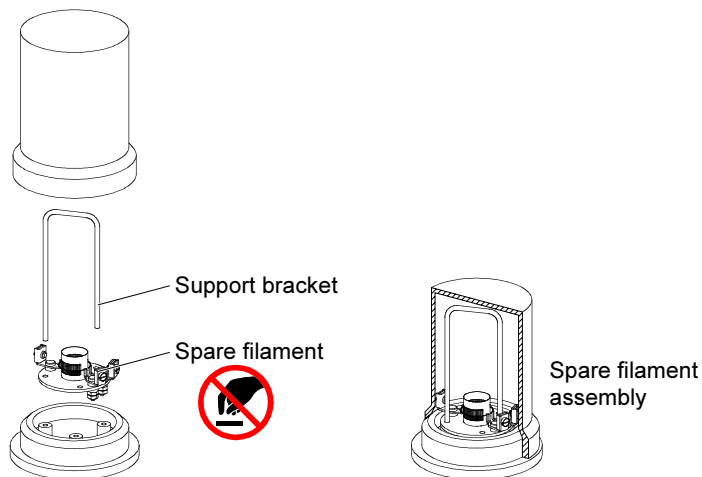

- 10 Mount the replacement filament on the ion source. Slide the filament assembly toward the setscrews so that the plate of the filament assembly is parallel to the plate of the ion source.



Caution

Do not twist the filament assembly, otherwise the ionization chamber will be deformed.

- 11 Mount the 3 nuts on the setscrews and tighten them with the special socket wrench.
- 12 Grip the U-sections with flat-nose pliers, introduce the electrical connections of the filament laterally at the U-sections and tighten the screws.

5.2 QME

5.2.1 Cleaning the Housing

DANGER

Disconnect the 24 V power supply of the QME from the AC power source before any moist cleaning.

A slightly damp cloth normally suffices for cleaning the outside of the unit. Do not use any aggressive or scouring cleaning agents.



Make sure that no liquid can penetrate the product. Allow the product to dry thoroughly before putting it into operation again.

5.2.2 Cleaning the Dust Filter

The dust filter at the air intake must be cleaned whenever there is clearly visible contamination layer. Use a vacuum cleaner to extract the dust from the filter. For this work it is not necessary to detach the QME from the QMA.

WARNING

Do not forget this cleaning, even if the unit is installed in such a way that the contamination cannot be easily seen.

5.2.3 Replacing the Filter Mat

Replace the filter mat if it is decomposed or if it can no longer be cleaned as described above.

- 1** Disconnect the 24 V power supply from the AC power source and detach all electrical connections to the QME.
- 2** Separate the QME from the analyzer by performing the steps described in Chapter 3.2.4 in reverse order.
- 3** Set the QME on a flat surface with the front panel facing upward.

- 4** Remove the screws shown in the opposite illustration (be careful not to lose the lock washers) and remove the front panel.

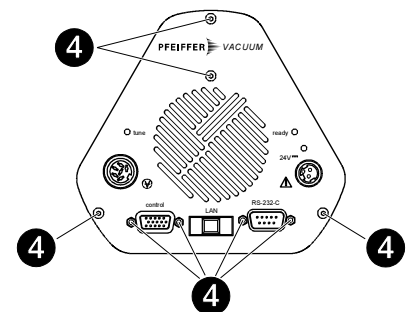

- 5** Replace the filter mat, which is now accessible.
- 6** Reassemble the unit by performing the above steps in reverse order. Do not forget to reinstall the lock washers.

5.2.4 Tuning the RF Generator

Correct tuning assures optimum measurement accuracy over the entire mass range. The RF circuit has to be tuned:

- upon exchange of the analyzer or electronics^{*)}
- when a corresponding error message is displayed.

An annual tuning check is also recommended.

1 Remove the small cap at the side of the QME. This hole gives access to the tuning screw.

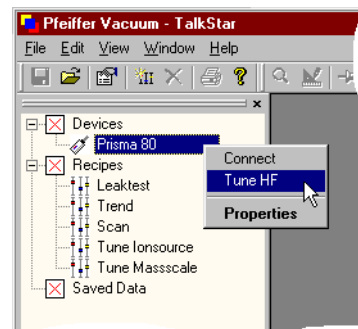

2 Start the TalkStar software. In the context menu of "Devices", click "Tune HF" with the right mouse button.





3 Use the  lamp of the QME as tuning indicator.

 **Caution**

Turn the tuning screw carefully, no force is required. Do neither fully tighten nor unscrew it completely.



  tune ⇒ slightly detuned. Turn the tuning screw ...

- clockwise until the lamp is on
- counterclockwise until the lamp is off and continue turning until the lamp is on again
- clockwise by one full turn

✓ The RF generator is now tuned ⇒   tune.

  tune ⇒ severely detuned. Turn the tuning screw ...

- clockwise to the stop
- counterclockwise until the lamp is off and continue turning until the lamp is on again
- clockwise by one full turn

✓ The RF generator is now tuned ⇒   tune.

4 Reinstall the cap.

5 After tuning the RF generator, quit the "Tune" mode with "OK".

^{*)} If the analyzer and electronics have not been delivered together as one unit, the RF circuit has to be tuned when the unit is put into service for the first time.

5.2.5 Optimizing the Ion Source Sensitivity

When the Prisma is used for the first time, the factory parameter settings of the ion source are applied. TalkStar reads these parameter values when it starts communication with the Prisma.

- 1 Start TalkStar. In the tree, select "Recipes" and start "Tune Ionsource" with a double click.

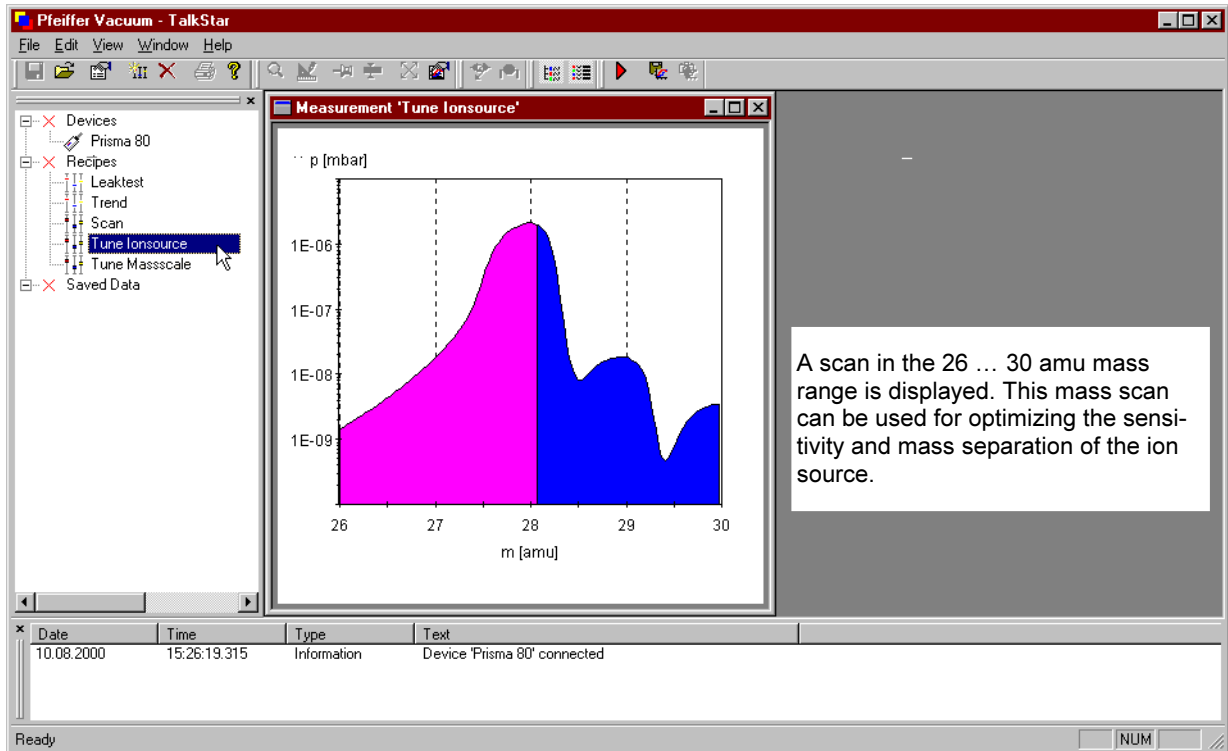

- 2 In the context menu of "Devices", click "Properties" with the right mouse button. In the window that is subsequently displayed, choose the "Ionsource" page.

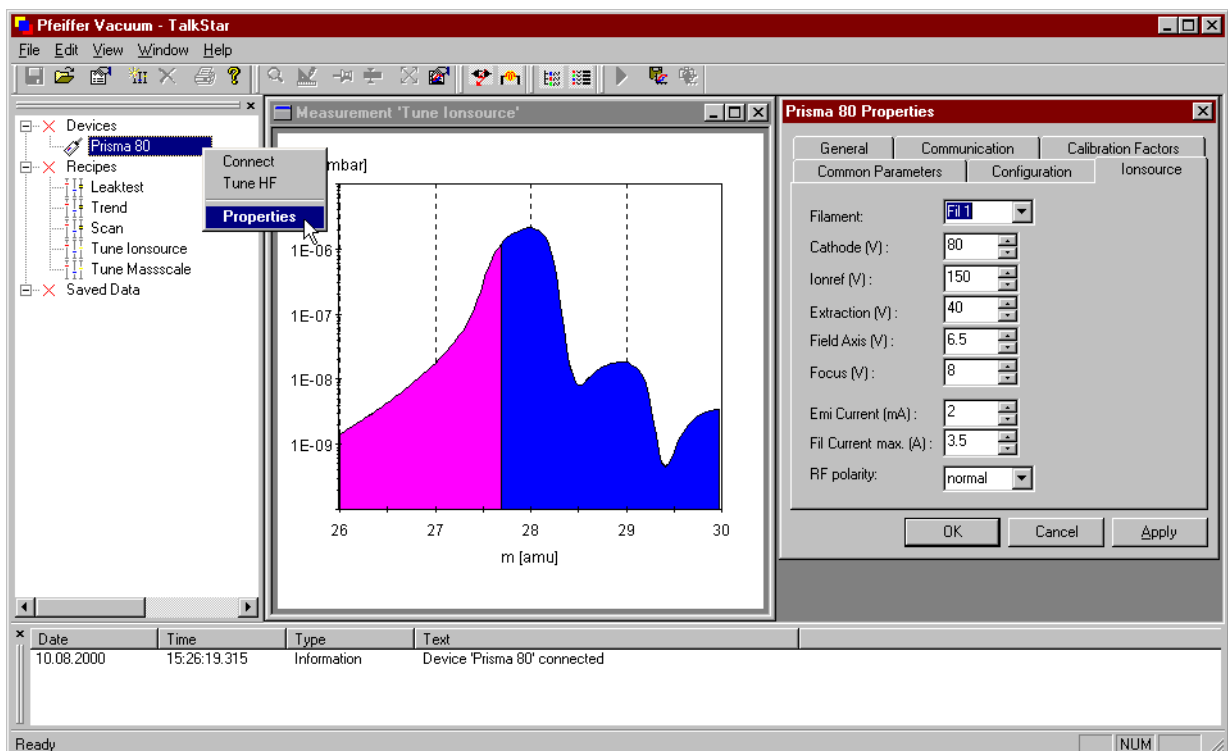

3 If "Emission Error" is displayed several times:

Date	Time	Type	Text
09.08.2000	13:24:29.649	Information	Device 'Prisma 80' connected
09.08.2000	13:31:25.272	Information	Device 'Prisma 80' error: Emission error (39)

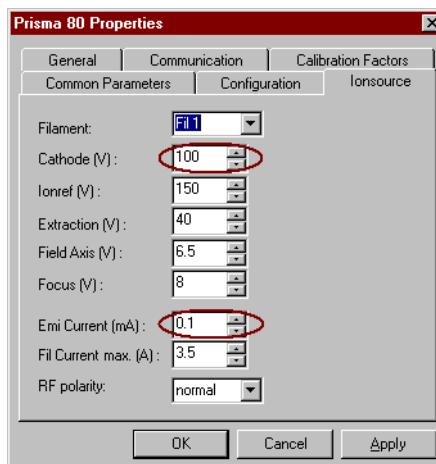

- Set the "Cathode" value to 100 V.
- Set the "Emi Current" value to 0.1 mA.
- Start the emission.
- Increase the "Emi Current" value in small increments to 2 mA.

4 Wait until the pressure in the vacuum system is $<1 \times 10^{-7}$ mbar.

5 If possible, admit air as test gas until the pressure in the vacuum system is 1×10^{-6} mbar.

After each of the following steps, transmit the parameter modifications to the Prisma™ 80 by clicking .

6 Optimize the "Cathode" value to the maximum peak height.



Low "Cathode" values can lead to a deactivation of the emission. In such a case, increase the value and reactivate the emission.

7 Intermittently optimize "Extraction" and "Focus" to the maximum peak height.

8 Beginning at 8 V, decrease the "Field Axis" value until the resolution and peak shape are satisfactory.



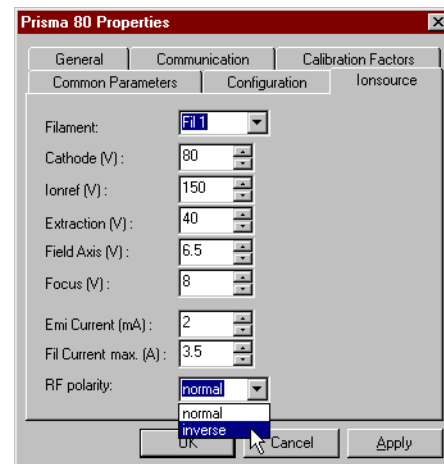

9 Change the "RF polarity" and select the setting which yields the better peak shape and resolution

✓ The optimization of the ion source is now concluded.



5.2.6 Replacing the QME

If the QME or QMA needs to be replaced, the procedure is the same as for the initial installation. The individual steps are:

- ❶ Installing the QME →  13.
- ❷ Connecting the QME →  13.
- ❸ Tuning the RF generator →  25.
- ❹ Optimizing the ion source →  26.

6 Accessories and Spare Parts

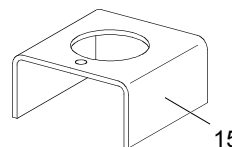
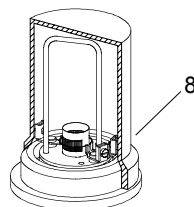
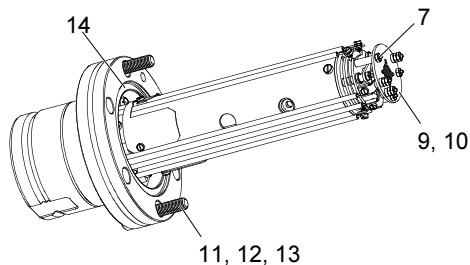
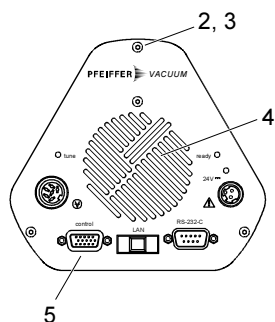
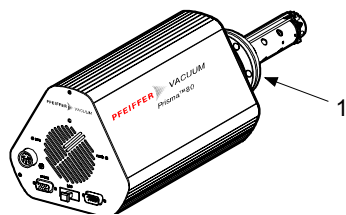

Item	Designation		E/Z	Ordering number
1	Hexagon socket screw key	M5 (size 4)	A	N 5701 009 BC
2	Hexagon socket screw	M3×8	A	B 3079 191 X
3	Lock washer	M3	A	B 3547 137 X
4	Filter mat		S,A	B 5099 154 FE
5	D-Sub connector, complete	15 pin	A	BG 442 639 -T
7	Socket wrench	size 3 / 3.2	A	BK 370 096
8	Filament assembly, complete iridium, yttriated		S	BN 846 138 -T
9	Misc. ion source small parts		A	
10	Ion source HS-Ir		S	BN 846 137 -T
11	Hexagon screw	M6×35	A	N 3015 349 X
12	Hexagon nut	M6	A	N 3415 043 X4
13	Washer	M6	A	N 3502 418 X
14	Cu seal	DN 40 CF	A	BP 414 606 -T
15	QMA mounting tool SP 200		A	BG 444 456
			S	B 5181 408 KY

A = Supplied accessory
S = Spare part

7 Returning the Product

WARNING

Caution: forwarding contaminated products

Contaminated products (e.g. radioactive, toxic, caustic or microbiological hazard) can be detrimental to health and environment.

Products returned to Pfeiffer Vacuum should preferably be free of harmful substances. Adhere to the forwarding regulations of all involved countries and forwarding companies and enclose a duly completed declaration of contamination (→ 32).

Products that are not clearly declared as "free of harmful substances" are decontaminated at the expense of the end-user.

Products not accompanied by a duly completed declaration of contamination are returned to the sender at his own expense.

8 Disposal

DANGER

Caution: contaminated parts

Contaminated parts can be detrimental to health and environment.

Before beginning to work, find out whether any parts are contaminated. Adhere to the relevant regulations and take the necessary precautions when handling contaminated parts.

WARNING

Caution: substances detrimental to the environment

Products or parts thereof (mechanical and electric components, operating fluids etc.) can be detrimental to the environment.

Dispose of such substances in accordance with the relevant local regulations.

Separating the components

After disassembling the product, separate its components according to the following criteria:

Contaminated components



Contaminated components (radioactive, toxic, caustic, or biological hazard etc.) must be decontaminated in accordance with the relevant national regulations, separated according to their materials, and disposed of.

Other components

Such components must be separated according to their materials and recycled.

Appendix

A: Literature

-  [1] www.pfeiffer-vacuum.de
Communication Protocol
Prisma™ 80 Quadrupole Mass Spectrometer
BG 805 206 BE
Pfeiffer Vacuum GmbH, D-35614 Asslar, Deutschland
-  [2] Brochure
Partial Pressure Measurement in Vacuum Technology
vznb01e1

Declaration of Contamination

The service, repair, and/or disposal of vacuum equipment and components will only be carried out if a correctly completed declaration has been submitted. Non-completion will result in delay.
 This declaration may only be completed (in block letters) and signed by authorized and qualified staff.

1 Description of product

Type _____

Part number _____

Serial number _____

2 Reason for return

3 Operating fluid(s) used (Must be drained before shipping.)

4 Process related contamination of product

toxic	no <input type="checkbox"/> 1)	yes <input type="checkbox"/>	<p>2) Products thus contaminated will not be accepted without written evidence of decontamination!</p>
caustic	no <input type="checkbox"/> 1)	yes <input type="checkbox"/>	
biological hazard	no <input type="checkbox"/>	yes <input type="checkbox"/> 2)	
explosive	no <input type="checkbox"/>	yes <input type="checkbox"/> 2)	
radioactive	no <input type="checkbox"/>	yes <input type="checkbox"/> 2)	
other harmful substances	no <input type="checkbox"/> 1)	yes <input type="checkbox"/>	

1) or not containing any amount of hazardous residues that exceed the permissible exposure limits

The product is free of any substances which are damaging to health
 yes

5 Harmful substances, gases and/or by-products

Please list all substances, gases, and by-products which the product may have come into contact with:

Trade/product name Manufacturer	Chemical name (preferably with formula)	Precautions associated with substance	Action in case of human contact

6 Legally binding declaration:

We hereby declare that the information on this form is complete and accurate and that we will assume any further costs that may arise. The contaminated product will be dispatched in accordance with the applicable regulations.

Organization/company _____

Address _____ Post code, place _____

Phone _____ Fax _____

E-mail _____

Name _____

Date and legally binding signature _____
Company stamp _____

Declaration of Conformity



We, Pfeiffer Vacuum, hereby declare that the equipment mentioned below complies with the provisions of the Directive relating to electrical equipment designed for use within certain voltage limits 73/23/EEC and the Directive relating to electromagnetic compatibility 89/336/EEC.

Product

Prisma™ 80

Quadrupole Mass Spectrometer

QMS 200

Part number

PTM04100

Standards

Harmonized and international/national standards and specifications:

- EN 61010 (Safety requirements for electrical equipment for measurement, control and laboratory use)
- EN 50081-1 (Electromagnetic compatibility generic emission standard)
- EN 50082-2 (Electromagnetic compatibility generic immunity standard)

Signature

Pfeiffer Vacuum GmbH, Asslar

18 June 2001

Wolfgang Dondorf
Managing director

Notes

Notes

Original: German BG 805 204 BD / B (0203)



bg805204be/b

PFEIFFER  **VACUUM**

*Berliner Strasse 43
D-35614 Asslar
Deutschland
Tel +49 (0) 6441 802-0
Fax +49 (0) 6441 802-202
info@pfeiffer-vacuum.de*

www.pfeiffer-vacuum.de